

## Pharmaceutical & Sanitary Check Valves

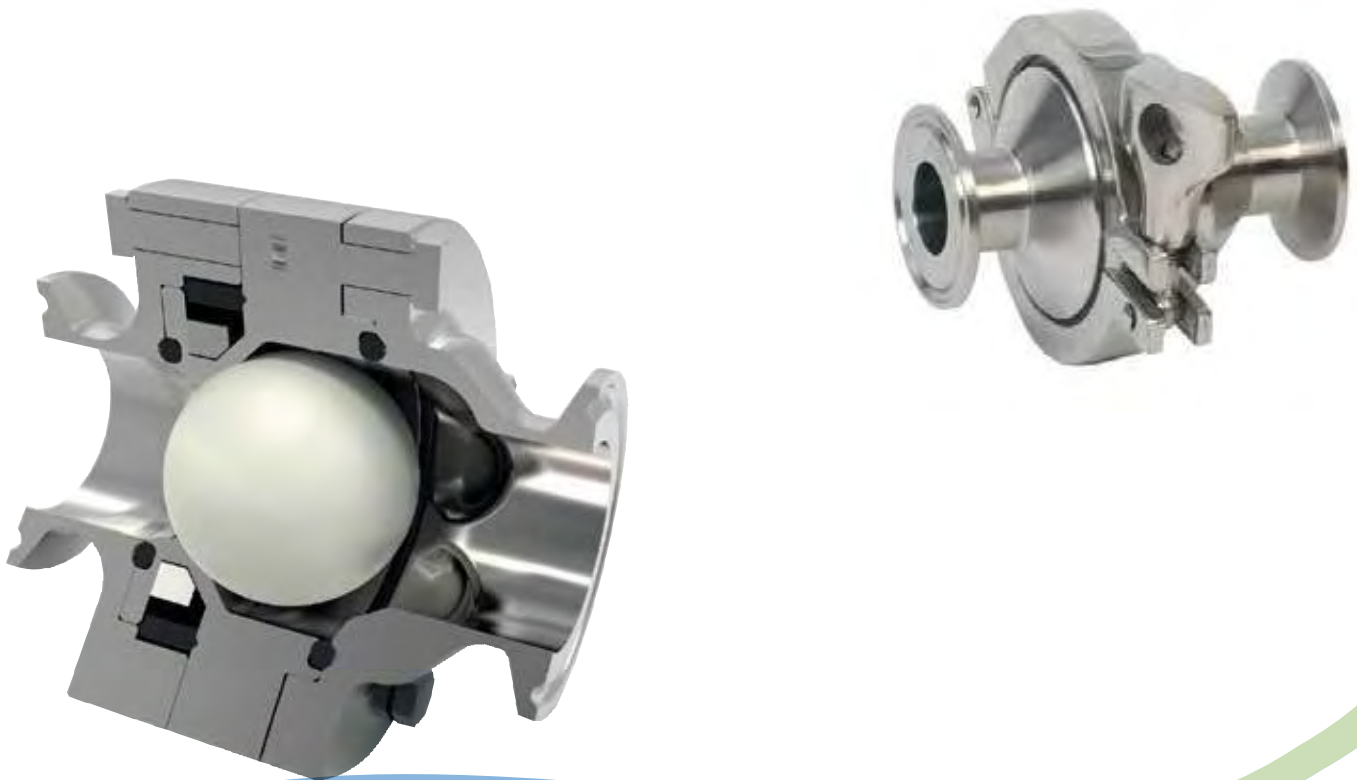



# Contents

<b>Pharmaceutical</b> . . . . .	<b>5</b>
High Purity Evolution . . . . .	6
of check Valve . . . . .	6
High Purity Evolution . . . . .	7
of check Valve . . . . .	7
WAFER Check Valve . . . . .	8
WAFER Check Valve . . . . .	9
<b>Sanitary</b> . . . . .	<b>11</b>
3S . . . . .	12
3S . . . . .	13
3S . . . . .	14
TC/SB Insert Valve . . . . .	15
EDF Non-Return Valve . . . . .	16
EDF Non-Return Valve . . . . .	17
C3 Cartridge Valve . . . . .	18
C3 Cartridge Valve . . . . .	19
AGGROBALL . . . . .	20
AGGROBALL . . . . .	21
CHECK VALVES . . . . .	22
C00 . . . . .	23
C00 . . . . .	24
YSV . . . . .	25
YSV ECCENTRIC . . . . .	29
YSV 3A . . . . .	31





**Pharmaceutical**



### Benefits at a Glance

- **Maximum Hygiene:**

Only the shutter comes into contact with the product. There are no springs, discs or other components, which means no contamination and no stagnation point. Top quality surface finishings and materials (PVDF and 1.4435 with < 1% Ferrite)

- **Safe Closing:**

Provided by integral magnets

- **Any installation position possible:**

Unlike other spring less check valves, a Pharmaball Valve can be installed in the horizontal, vertical up and down positions

- **Energy saving:**

The innovative working principle and design allow for a smooth flow, minimising pressure drop

- **Laminar flow:**

No turbulence

- **Maintenance free**

- **Extra high chemical resistance and longer valve life:**

Through solid construction materials



Pharmaball patented technology sets new standards in the world of plant design, thanks to a patented magnetic principle replacing the conventional spring in Non Return Valves. Suitable for horizontal, vertical up and down installation (even in vertical pipes with flow down). For fluids and steam, up to +150°C.

### TECHNICAL DATA

Product contact materials	Body & Flanges: Stainless steel 1.4435 (AISI 316LM), max. <1% ferrite Ball: PVDF
Non product contact materials	Magnet: Neodymium
Seals material options	EPDM, NBR, HNBR, VMQ (Silicone), FKM (Viton), FEP, PTFE
Surface finishes	Internal: Ra $\mu\text{m} \leq 0.4$ electropolished External: Ra $\mu\text{m} \leq 1.2$ electropolished  Passivation or request (optional)
End connection options	WELDING DIN 11850 (DIN 11866 Reihe A) WELDING DIN 11850 (DIN 11866 Reihe C) TRI-CLAMP ASME-BPE
Temperature range	-40°C/+150°C/
Operating pressure	PN16 (standard). Further operating pressure on request
Media	Fluids, Gas, Steam
Certifications (on request)	Materials: (EN10204-3.1)/seals and PVDF Ball (FDA - USP VI) Surface roughness EC 1935/2004

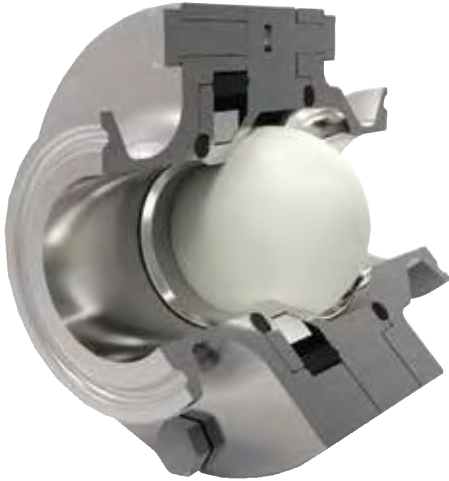

**PHARMABALL: STANDARD OPENING PRESSURES**  
Table applies to water at 20° C (68°F)

Installation	Flow direction	Opening pressure
HORIZONTAL lines	→←	30/50 mbar
VERTICAL lines	Flow Down	27/45 mbar
VERTICAL lines	Flow up	33/55 mbar

Once opened, the required pressure to keep the shutter fully open is about 10 mbar.



**PRESSURE DROP CHART**

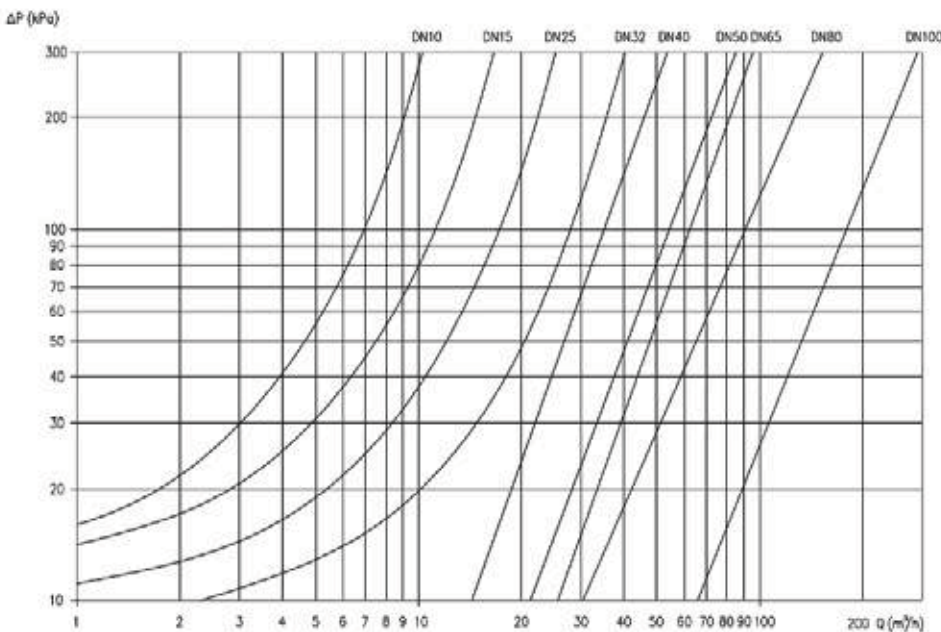

### Benefits at a Glance

- **No chatter:**  
The magnetic principle is particularly suitable for compressible media (such as gas) or low pressure processes. Very low difference pressure needed to keep the disc fully open
- **High chemical resistance/ longer valve life:**  
Due to the 1.4404 (AISI 316L)/ 1.4462 (Duplex) construction
- **Safe Closing:**  
Provided by integral magnets
- **Any installation position possible:**  
Unlike other springless check valves, a Wafer can be installed in the horizontal, vertical up and down positions
- **Energy saving (laminar flow):**  
The innovative working principle and design allow for a smooth flow, minimising pressure drop
- **Laminar flow:**  
No turbulence
- **Maintenance**



Pharmaball patented technology sets new standards in the world of plant design, thanks to a patented magnetic principle replacing the conventional spring in Non Return Valves.  
Suitable for horizontal, vertical up and down installation (even in vertical pipes with flow down).  
For fluids and steam, up to +150°C.

### TECHNICAL DATA

Product contact materials	Body: Stainless steel 1.4404(AISI 316LM) Shutter: 1.4462 (Duplex)
Non product contact materials	Magnet: Neodymium
Seals material options	EPDM, NBR, HNBR, VMQ (Silicone), FKM (Viton), FEP, PTFE
Surface finishes	Internal: Ra $\mu\text{m} \leq 1.6$ External: Ra $\mu\text{m} \leq 3.2$
Temperature range	-40°C/+150°C(standard) Up to +220°C(optional)
Operating pressure	PN16 (standard). Further operating pressures on request
Media	Fluids, Gas, Steam
Certifications (on request)	Materials: (EN10204-3.1)/seals (FDA) Surface roughness ATEX EC 1935/2004



### WAFER: STANDARD OPENING PRESSURES

Table applies to water at 20° C (68°F)

Installation	Flow direction	Opening pressure
HORIZONTAL lines	←	10/30 mbar
VERTICAL lines	Flow Down	7/27 mbar
VERTICAL lines	Flow up	13/33 mbar

Once opened, the required pressure to keep the shutter fully open is about 10 mbar.

### PRESSURE DROP CHART

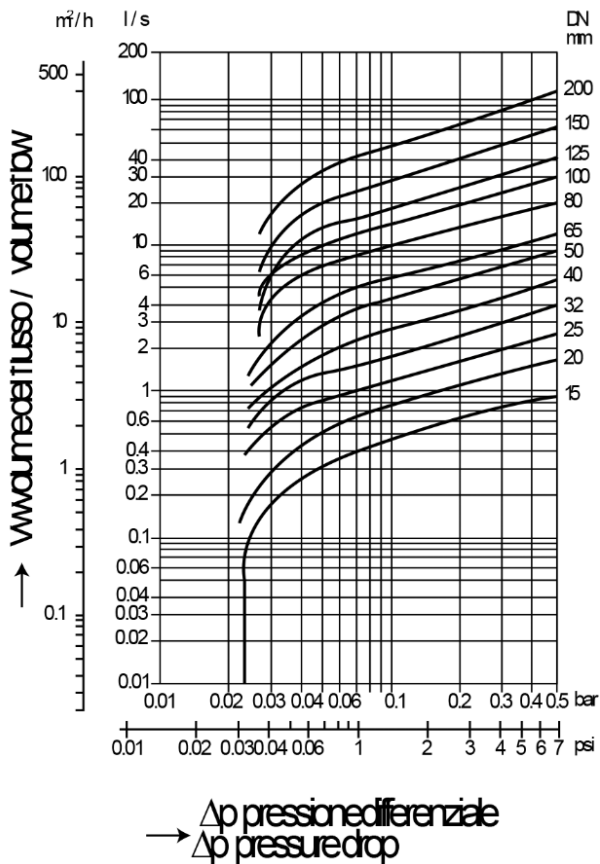



## Sanitary





### Disassembly For Cleaning Instructions

To disassemble the 3-A Sanitary valve, start by depressing one side of the retainer as shown in Step 1. With one side of the retainer tipped, rotate the stem of the poppet and remove the retainer as shown in Steps 2, 3 and 4. To reassemble the valve reverse the process. Consult the factory for information on trim kits, o-ring kits, or individual spare parts.

#### VALVE PARTS

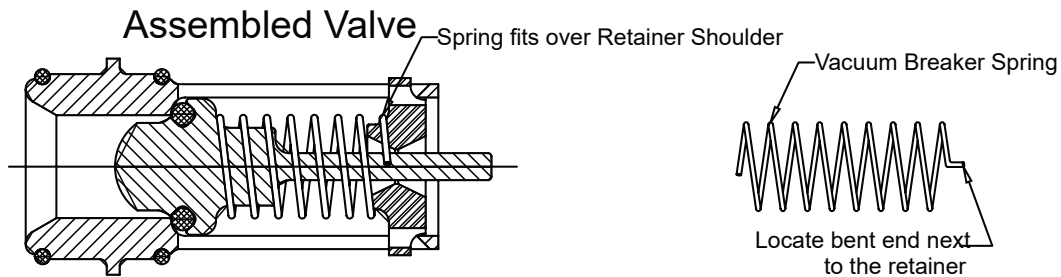
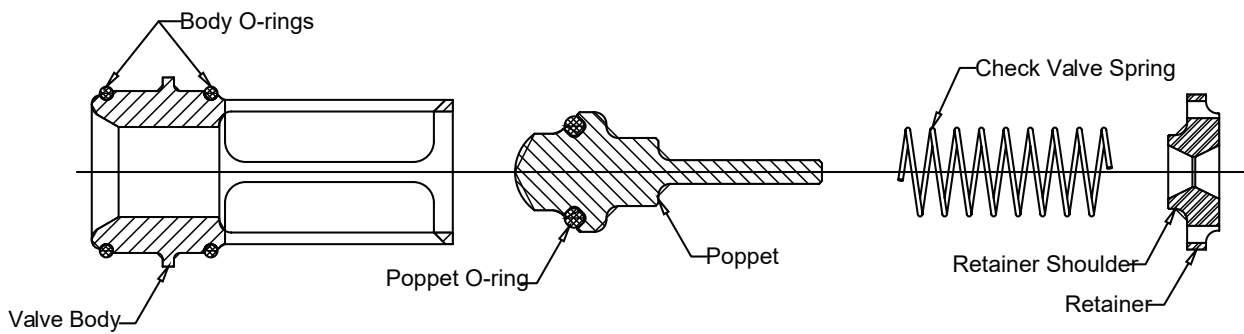

Step 1

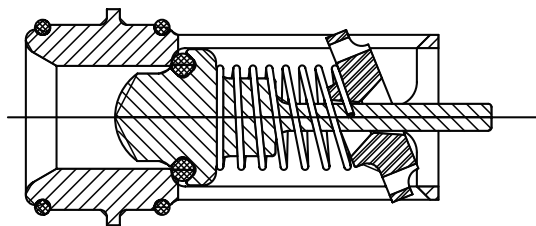

Step 2

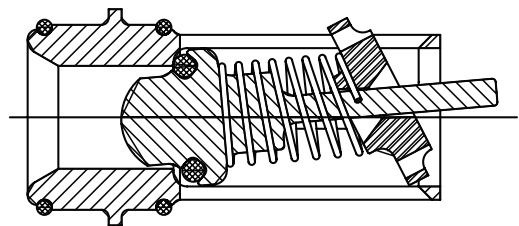

Step 3

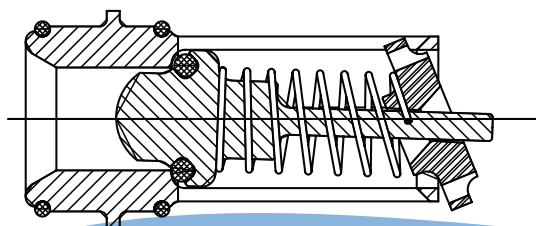

Step 4

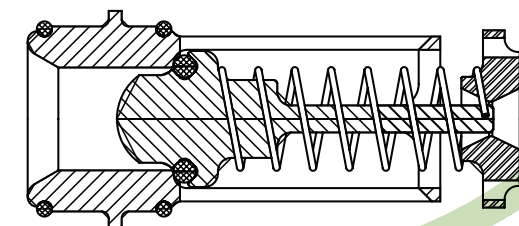

**3-A Sanitary  
For Water at 72°F**

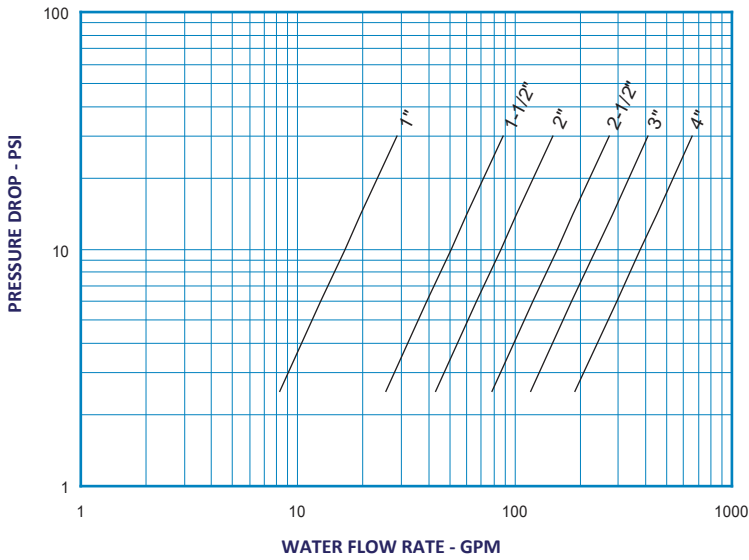

STYLE 3S C <sub>v</sub> VALUES & VALVE WEIGHTS		
C <sub>v</sub>	SIZE	316/316L SS
5.2	1"	2.3 oz.
16.1	1-1/2"	6.2 oz.
27.2	2"	13.9 oz.
49.4	2-1/2"	1.5 lb.
74.9	3"	1.9 lb.
120.0	4"	3.9 lb.

Valve weights are approximate.

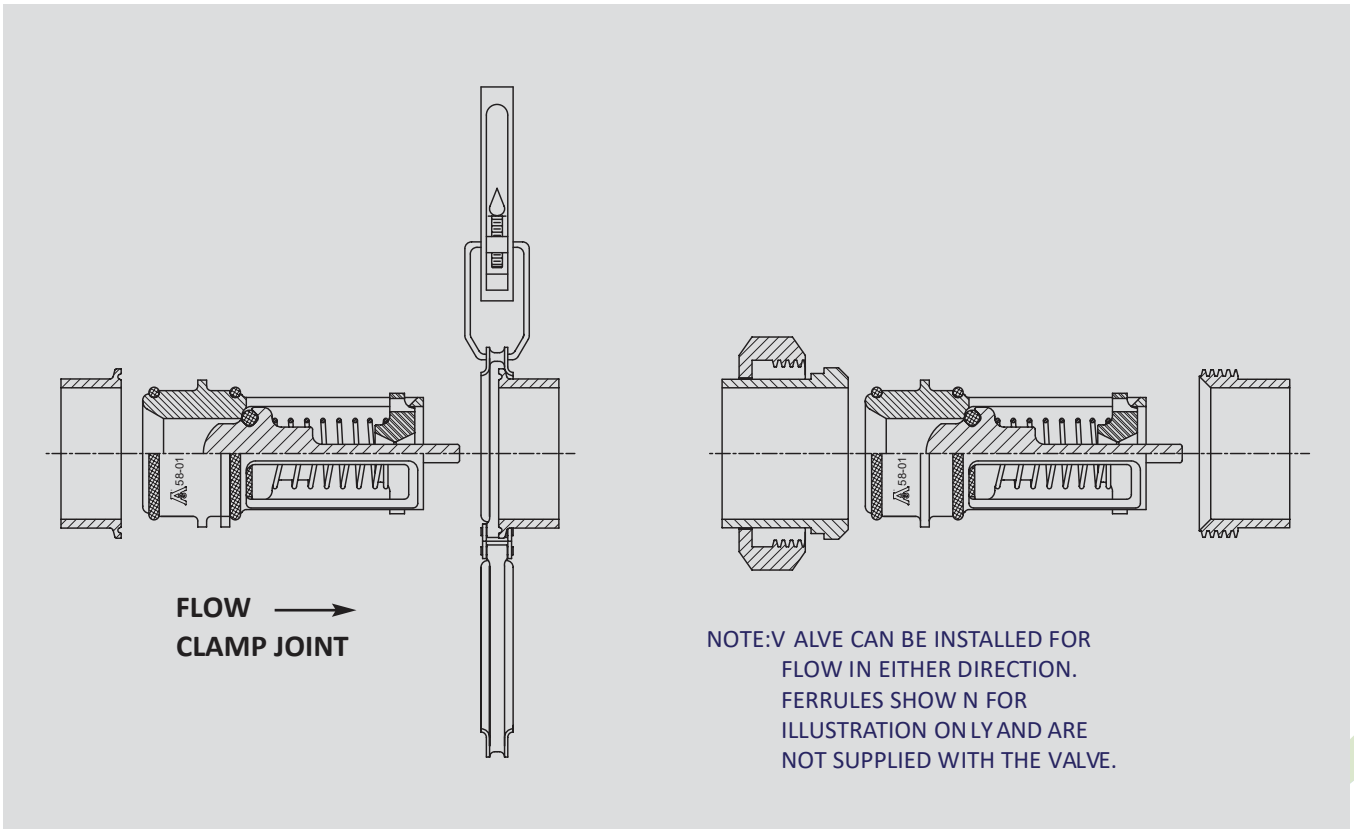

Sanitary

TC/SB Insert Valve

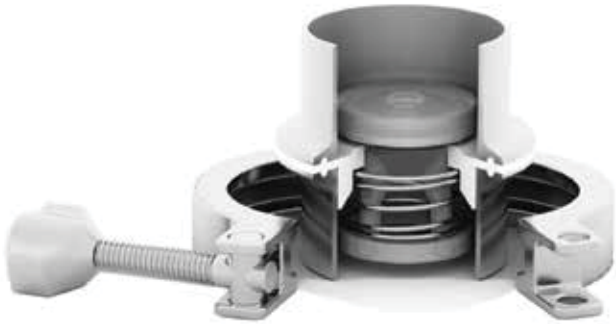

Valve shown in ferrules. Ferrules and clamp not included.

The Sanitary Insert (CB, TC) valve is a compact fluoropolymer (PTFE/FEP/PFA) valve which has been used for over 45 years as the most economical solution for providing a check valve in a new or existing sanitary piping system. This valve style is designed to fit into grooved-end clamp-type fittings (ferrules not included). Since the Sanitary Insert Valve replaces the gasket normally used with clamp joints, no extra space is required to accommodate the valve. The Sanitary Insert valve can also be used as a low pressure relief valve or vacuum breaker by using the desired spring settings. Two different types of Sanitary Insert Valves are available. They are distinguished by the following designations in their part numbers: TC - Designates Tri-Clamp® fittings manufactured by Alfa Laval Inc., CB - Designates the Waukesha Cherry-Burrell® as well as Waukesha Cherry-Burrell® S-Line Series of fittings. Q-Line Series of fittings.

NOTE: Sanitary Insert Valve types TC and CB are not interchangeable!

Body Material <b>e</b>	Line Size	Non-Shock Pressure - Temperature Rating <b>f</b>
PTFE (TF)	3/4" - 2"	55 PSIG @ 100°F
	2-1/2" - 4"	20 PSIG @ 100°F

**e:** See page 54 for material grade information.  
**f:** Consult the factory for reduced P -T rating of PTFE valves above 100°F.

Line Size	Size Code	TC - Alfa Laval Inc. Waukesha Cherry-Burrell® S-Line					CB - Waukesha Cherry-Burrell® Q-Line Only					Orifice Diameter	
		A	B	C	D	w	E	A	B	C	D		w
3/4"	F	0.590	55/64	0.55	0.63	0.800	-	-	-	-	-	-	0.348
1"	H	0.855	2	0.55	0.70	1.718	0.850	1-3/4	0.55	0.70	1.437	0.464	
1 1/2"	J	1.345	2	0.60	0.98	1.718	1.350	2	0.60	0.98	1.716	0.890	
2"	K	1.845	2-1/2	0.57	1.12	2.218	1.850	2-1/2	0.57	1.12	2.247	1.135	
2 1/2"	L	2.355	3	0.60	0.98	2.781	2.250	3-1/4	0.60	0.98	2.841	1.385	
3"	M	2.845	3-1/2	0.64	1.59	3.281	2.852	3-55/64	0.61	1.58	3.372	2.025	
4"	N	3.806	4-5/8	0.78	1.90	4.344	3.800	4-55/64	0.73	1.89	4.372	2.560	

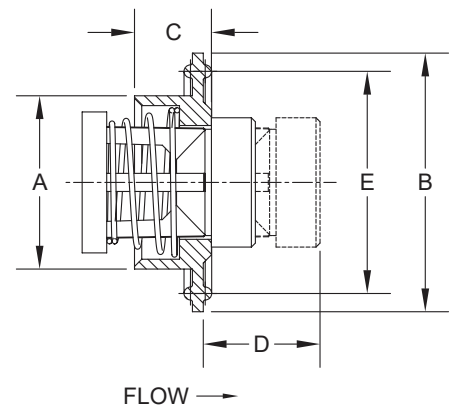

**q:** Due to molding process, orifice may vary.  
**w:** Maximum nominal dimension for a fully open valve with no spring.

Sanitary Insert Valve For Water at 72°F

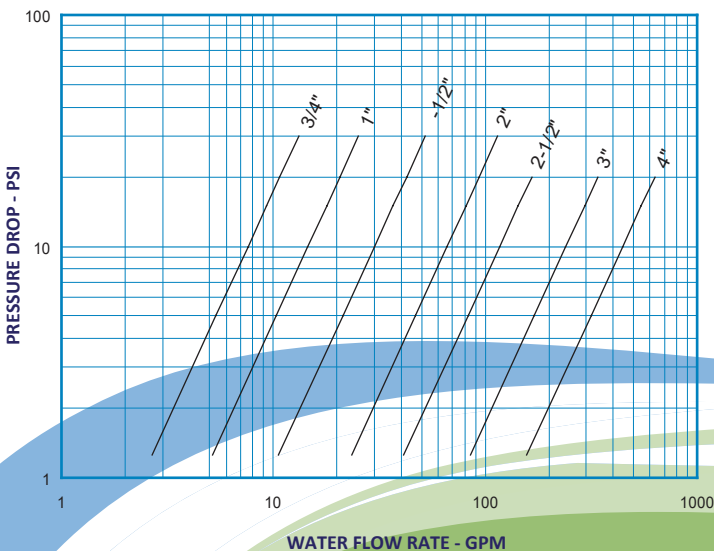

STYLE 3S C<sub>v</sub> VALUES & VALVE WEIGHTS

C <sub>v</sub>	SIZE	316/316L SS
2.4	3/4"	0.2 oz.
4.6	1"	0.6 oz.
9.5	1-1/2"	1.1 oz.
20.9	2"	1.8 oz.
37.0	2-1/2"	2.3 oz.
77.9	3"	5.1 oz.
141.0	4"	11.2 oz.

Valve weights are approximate.

### Benefits at a Glance

- Maximum hygiene (spring free design):**  
 Only the shutter comes into contact with the product. There are no springs, discs or other components, which means no contamination and no stagnation point
- Safe Closing:**  
 Provided by integral magnets
- Any installation position possible:**  
 Unlike other springless check valves, EDF non-return valve can be installed in the horizontal, vertical up and down positions
- Energy saving:**  
 The innovative working principle and design allow for a smooth flow, minimising pressure drop
- Laminar flow:**  
 No turbulence
- Maintenance free:**  
 Longer valve life



### TECHNICAL DATA

Product contact materials	Body & Flanges: Stainless steel 1.4404(AISI 316LM) Shutter: 1.4462 (Duplex)
Non product contact materials	Magnet: Neodymium
Seals material options	EPDM, NBR, HNBR, VMQ (Silicone), FKM (Viton), FEP, PTFE
Surface finishes	Internal: Ra $\mu\text{m} \leq 0.8 \mu\text{m}$ (standard), up to Ra $\leq 3.2$ electropolished and passivated (optional) External: Ra $\mu\text{m} \leq 3.2 \mu\text{m}$ (standard), up to Ra $\leq 0.4$ electropolished and passivated (optional)
End connection options	WELDING DIN 11850 / DIN 11851 / ASME BPE / ISO 1127 / SMS TRI-CLAMP: ASME-BPE / ISO 1127-2852 / SMS-2852 / DIN 32676 THREADED: Female Din / Male Gas BSP 60° / Female Gas BSP 60°
Temperature range	-40°C/+150°C(standard). Up to +220°C (optional)
Operating pressure	PN16 (standard). Further operating pressures on request
Media	Liquid, Gas, Steam
Sizes	From DN06 to DN200 / From 1/2" to 8"
Certifications (on request)	Materials: (EN10204-3.1)/ Seals (FDA)/ Surface roughness 3A ATEX PED EC 1935/2004



### How the EDF Non-Return Valve Works

The magnets built into the valve body keep the shutter in a closed position. The EDF check valve opens when the inflow pressure exceeds the magnetic force. In the open position the shutter moves away from the magnet, which means lower attraction to the seat and therefore lower resistance to flow, so pressure drop is minimal.

When the forward flow in the pipe stops, the magnet will attract the shutter back to its seat, stopping any backwards flow.

The main operational difference between a spring loaded check valve and the innovative EDF valve is the resistance to flow. An ordinary check valve in the open position imposes significant resistance, because the compressed spring pushes the shutter against the flow with considerable force.

### EDF: STANDARD OPENING PRESSURES

Table applies to water at 20° C (68°F)

Installation	Flow direction	Opening pressure
HORIZONTAL lines	→←	30/50 mbar
VERTICAL lines	Flow Down	27/45 mbar
VERTICAL lines	Flow up	33/55 mbar

Once opened, the required pressure to keep the shutter fully open is about 10 mbar  
Alternative opening pressure options are available on request

### PRESSURE DROP CHART

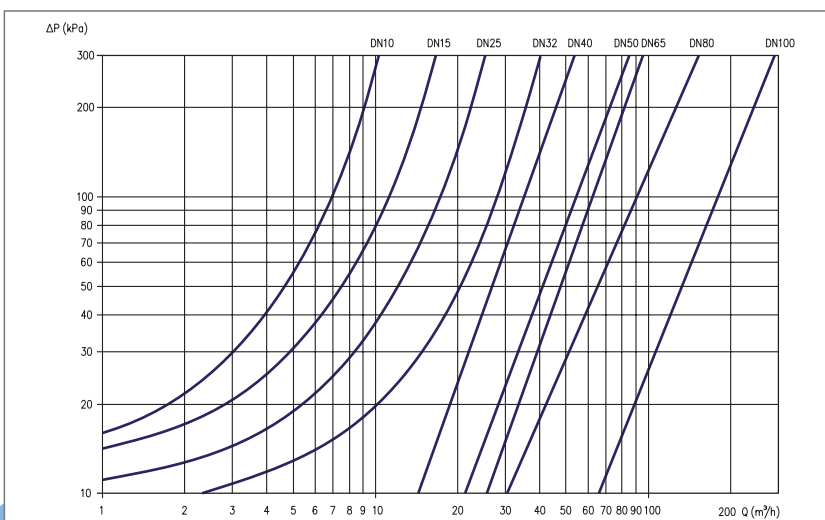

The C3 Sanitary Cartridge valve is stainless steel check valve for use with new or existing sanitary ferrules. The C3 design seals on the ID of ferrules with replaceable food grade seals (Standard is FDA EPDM). The valve fits to 3A,BPE Tri-Clamp® ferrules.

Bevel Seat ant Tri-Clamp® fittings, Waukesha Cherry-Burrell® Q-Line and S-Line and others with ID dimensions equal to the "F" dimensions listed below (ferrules not included).

The compact C3 design fits inside a single fitting and requires no additional space in the line. Its size makes it extremely economical when compared to full-bodied valve.

Note: USP Class VI o-rings can be supplied with certification.



**3-A Sanitary**  
For Water at 72°F

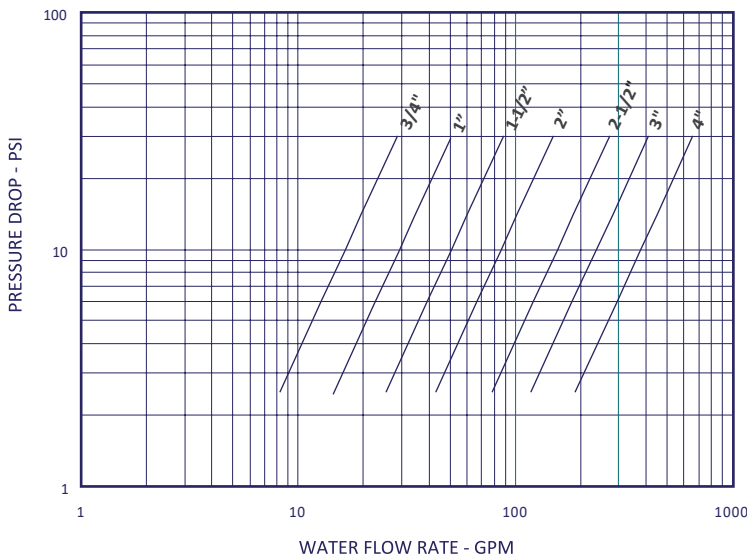

Note: All flow curves and Cv values presume the valves are fully open with 1/2 PSI cracking pressure springs. Consult the factory for more information

**STYLE 3S**  
**C<sub>v</sub> VALUES & VALVE WEIGHTS**

C <sub>v</sub>	SIZE	316/316L SS
2.4	3/4"	0.3 oz.
4.6	1"	1.0 oz.
9.5	1-1/2"	2.9 oz.
20.9	2"	6.1 oz.
37.0	2-1/2"	11.2 oz.
77.9	3"	11.4 oz.
141.0	4"	2.6 lb.

Body Material <b>†</b>	Line Size	Non-Shock Pressure - Temperature Rating <b>†*</b>
316/ 316L Stainless Steel (SS)	3/4" - 1-1/2"	1000 PSIG @ 100°F
	2" - 4"	725 PSIG @ 100°F

**\*†:** Consult the factory for applications where higher pressure or temperature is expected  
Note: 30 PSI is the maximum recommended pressure drop

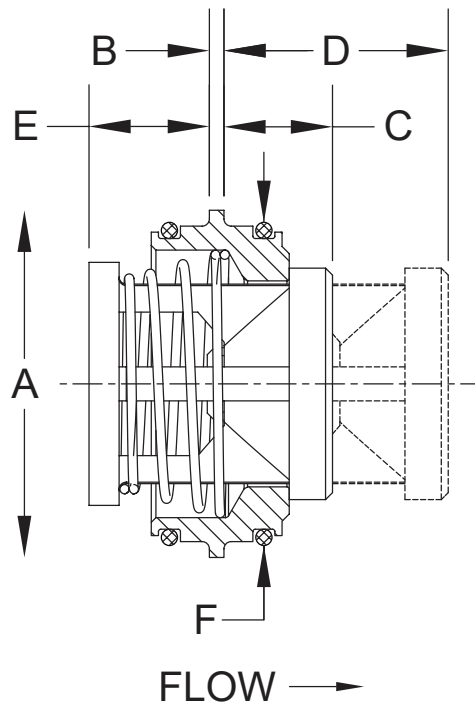

Line Size	Size Code	A	B	C q*	D w*	E	F e*	Orifice Diameter	Ordering Code
3/4"	F	3/4	1/16	0.44	0.78	0.28	0.620	0.348	V0200C3-0*0**-A54
1"	H	1	1/16	0.53	0.89	0.30	0.870	0.464	V0250C3-0*0**-A54
1½"	J	1½	1/16	0.53	1.06	0.63	1.370	0.890	V0380C3-0*0**-A54
2"	K	2	1/16	0.66	1.39	0.66	1.870	1.135	V0510C3-0*0**-A54
2½"	L	2½	1/16	0.69	1.56	0.88	2.370	1.385	V0630C3-0*0**-A54
3"	M	3	1/16	0.75	1.97	1.25	2.870	2.025	V0760C3-0*0**-A54
4"	N	4	1/16	0.88	2.41	1.63	3.834	2.560	V1000C3-0*0**-A54

\*q: Maximum nominal dimension for valve closed

\*w: Maximum nominal dimension for a fully open valve

\*e: Valves are designed to function with fittings having these internal diameters (±0.005)

**\* Refers to Crack pressure**

1.	Crack Pressure ½ PSI
2.	Crack pressure 1/4 PSI

**\* Refers to elastomer**

1.	Silicone Peroxide FDA
2.	Silicone Peroxide Class VI
3.	EPDM Class Vi
4.	EPDM FDA
5.	VITON CLASS VI
6.	VITON FDA

Listed above are the most common material selections. Please contact the factory for additional options.

q 500 PSI is the only standard cracking pressure for spring materials other than Stainless Steel, 125 PSI springs are not recommended for installations with flow vertical down

### Benefits at a Glance

- **Extra high chemical resistance and longer valve life:**  
Through solid construction materials (1.4435 and PVDF)
- **Safe Closing:**  
Provided by integral magnets
- **Any installation position possible:**  
Unlike other springless check valves, a Aggroball can be installed in the horizontal, vertical up and down positions
- **Energy saving:**  
The innovative working principle and design allow for a smooth flow, minimising pressure drop
- **Laminar flow:**  
No turbulence
- **Maintenance free**



### TECHNICAL DATA

Product contact materials	Body & Flanges: Stainless steel 1.4435(AISI 316LM), max. <1% ferrite Ball: PVDF
Non product contact materials	Magnet: Neodymium
Seals material options	EPDM, NBR, HNBR, VMQ (Silicone), FKM (Viton), FEP, PTFE
Surface finishes	Internal: Ra $\mu\text{m} \leq 0.8 \mu\text{m}$ External: Ra $\mu\text{m} \leq 3.2 \mu\text{m}$
End connection options	WELDING DIN 11850 (DIN 11866 Reihe A) WELDING ASME BPE (DIN 11866 Reihe C) TRI-CLAMP: ASME-BPE
Temperature range	-40°C/+150°C
Operating pressure	PN16 (standard). Further operating pressures on request
Media	Fluids, Gas, Steam
Certifications (on request)	Materials: (EN10204-3.1)/ seals and PVDF Ball (FDA - USP VI) Surface roughness EC 1935/2004

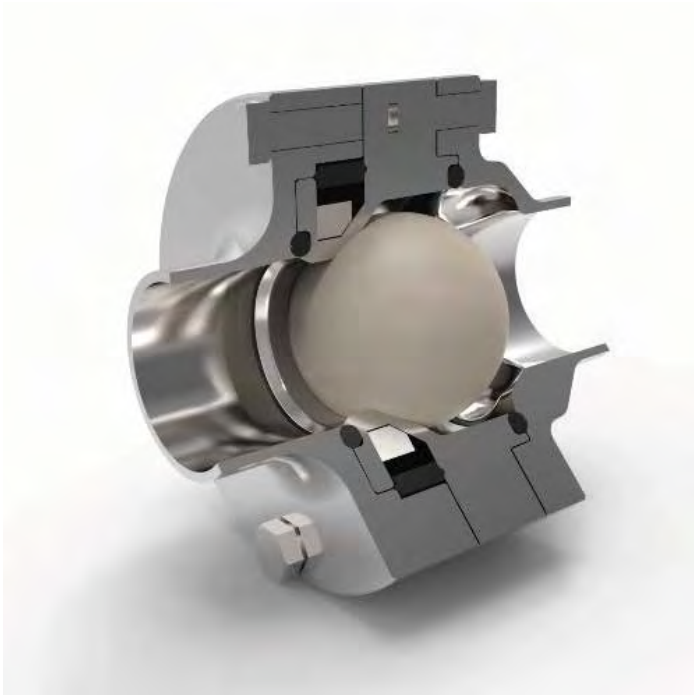

**PHARMABALL: STANDARD OPENING PRESSURES**  
**Table applies to water at 20° C (68°F)**

Installation	Flow direction	Opening pressure
HORIZONTAL lines		30/50 mbar
VERTICAL lines	Flow Down	27/45 mbar
VERTICAL lines	Flow up	33/55 mbar

Once opened, the required pressure to keep the shutter fully open is about 10 mbar.

**PRESSURE DROP CHART**

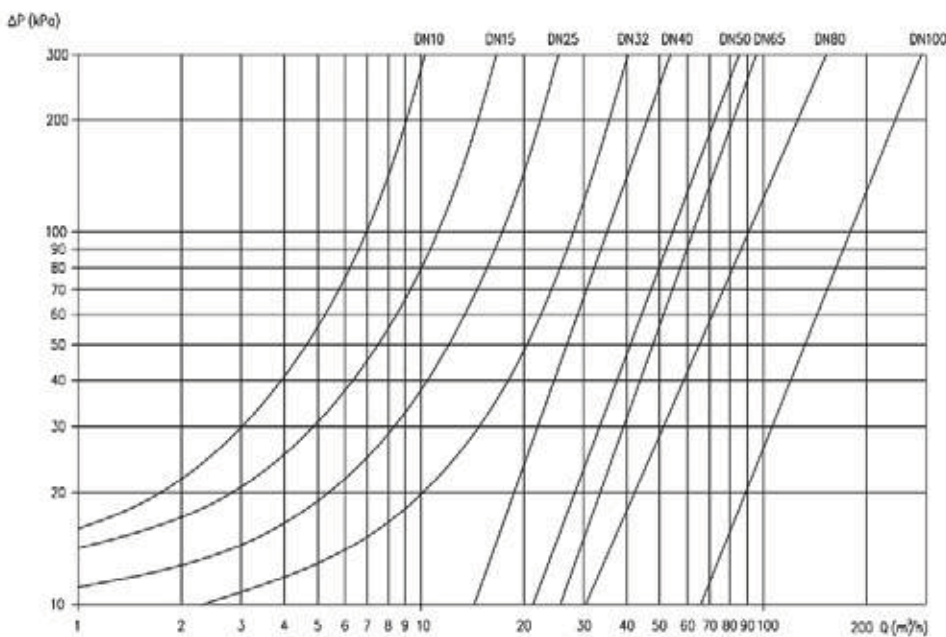

Graph reading applies to water at 20°C (68°F) installed in horizontal pipes

## Sanitary

## CHECK VALVES



Check Valve BioFlow VC



FlowStop

### Technical Data

<b>Installation</b>	BioFlow VC: vertical BioFlow HVC: horizontal
<b>Housing material*</b>	1.4405/316L
<b>FLOWstop material* Plug</b>	1.4404/316L with vulcanised seal EPDM (FDA + USP Class VI) PTFE (FDA + USP Class VI)
<b>Delta ferrite content (raw material)</b>	<1%
<b>Body area</b>	O-Ring EPDM (FDA + USP Class VI) Clean Lip (stainless steel sealing element)
<b>Max. permissible pressure</b>	PN16 (20°C)
<b>Opening pressure</b>	0.02 bar
<b>Max. operating temperature</b>	-10°C / +150°C
<b>Connections*</b>	Tri clamps , Orbital welding ends according to 3A
<b>Approvals</b>	TÜV-component testing(housing) EHEDG (housing)

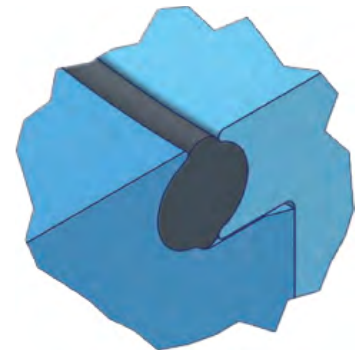

\* Alternative material grades (such as 2.4602, 2.4605, 1.4539, AL-6XN®, etc.), alternative sealing materials for body seal (such as Viton, Viton / FEP - encapsulated, PTFE, CleaLip®, etc.), as well as different connections, surface qualities and delta ferrite values are available on request

### CK3 Check valves (welded)

Nominal Size	L (Butt Welding End)	O	I	C	T	Ordering Code
0.5"	100	12.7	9.4	100	1.65	V015WC0-001*-A53
0.75"	100	19.1	15.8	100	1.65	V020WC0-001*-A53
1.0"	112	25.4	22.1	100	1.65	V025WC0-001*-A53
1.5"	115	38.1	34.8	100	1.65	V038WC0-001*-A53
2.0"	115	50.8	47.5	100	1.65	V051WC0-001*-A53

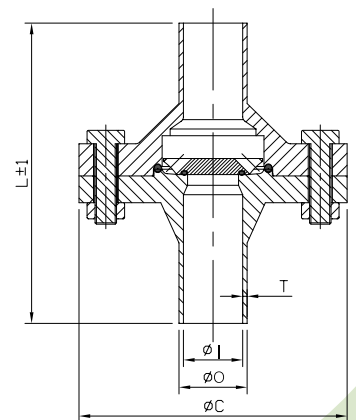

**Introduction**

The C00 Non-return Valve is a hygienic one-way check valve for use in various processes across the hygienic industries to prevent reverse flow. It is easy to install, ensuring safety and high product quality.

**Application**

The C00 Non-return Valve is widely used for single directional product flow through hygienic process lines across the dairy, food, beverage, brewery and many other industries

**Benefits**

- Highly reliable, self-acting valve
- Easy cleaning and assembly
- Easy to install
- Protects process equipment
- Prevents reverse flow
- Max. Working pressure 10 Kg/cm<sup>2</sup>.
- Working temperature -20°C + 180°C

**Standard design**

The C00 Non-return Valve consists of a valve body in two parts, valve plug and spring, assembled by means of a clamp ring and hygienically sealed with a special seal ring. A guide disc with four legs ensure alignment of the spring loaded valve plug with an o-ring seal. The valve is available with weld and clamp ends for ISO and DIN tubing connections.

**Working principle**

The C00 Non-return Valve opens and closes depending on the pressure. The spring acts on the valve plug and keeps the valve closed until the force from the pressure in the inlet exceeds the force of the spring. If a reverse flow should occur, the spring force and the pressure from the outlet will keep the valve closed.

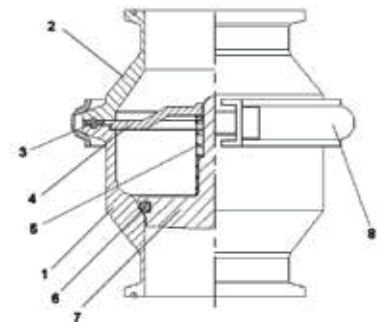

Size	L (Clamp End)	A	B	T	Ordering Code
1/2"	99.4	12.7	25.0	1.65	V015CC1-000*-A54
3/4"	95.4	19.1	25.0	1.65	V020CC1-000*-A54
1"	85.4	25.4	50.4	1.65	V025CC1-000*-A54
1 1/2"	100.4	38.1	50.4	1.65	V038CC1-000*-A54
2"	100.4	50.8	63.9	1.65	V051CC1-000*-A54
2 1/2"	100.4	63.5	77.5	1.65	V063CC1-000*-A54
3"	100.4	76.2	90.9	1.65	V076CC1-000*-A54
4"	150.6	101.6	118.9	2.11	V100CC1-000*-A54
6"	215.6	152.7	166.9	2.77	V150CC1-000*-A54

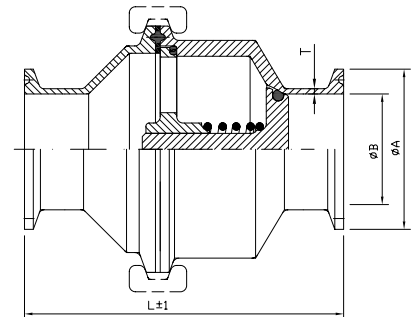

Size	L (Butt Welding End)	A	B	T	Ordering Code
1/2"	99.4	12.7	9.40	1.65	V015WC1-000*-A54
3/4"	95.4	19.1	15.80	1.65	V020WC1-000*-A54
1"	85.4	25.4	22.10	1.65	V025WC1-000*-A54
1 1/2"	100.4	38.1	34.80	1.65	V038WC1-000*-A54
2"	100.4	50.8	47.50	1.65	V051WC1-000*-A54
2 1/2"	100.4	63.5	60.20	1.65	V063WC1-000*-A54
3"	100.4	76.2	72.90	1.65	V076WC1-000*-A54
4"	150.6	101.6	97.38	2.11	V100WC1-000*-A54
6"	215.6	152.7	146.86	2.77	V150WC1-000*-A54

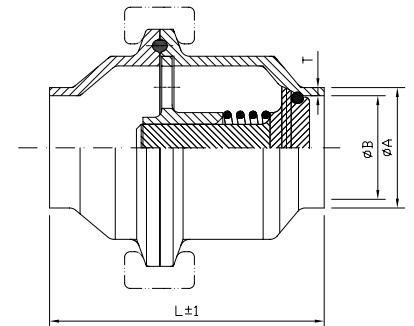

### Head Losses Diagram

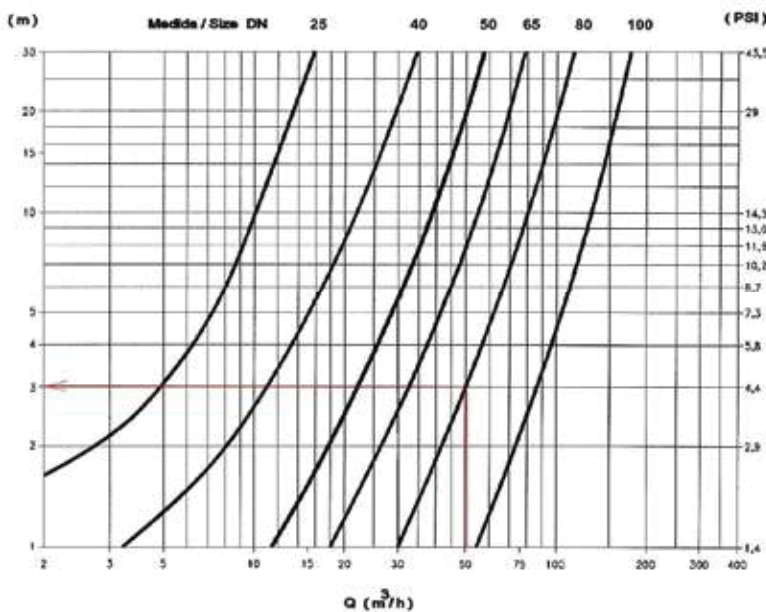

\* Refers to elastomer

1.	Silicone Peroxide FDA
2.	Silicone Peroxide Class VI
3.	EPDM Class Vi
4.	EPDM FDA
5.	VITON CLASS VI
6.	VITON FDA
7.	TEFLON CLASS VI
8.	Teflon FDA

### TECHNICAL DATA

Max. temperature:	120°C (EPDM)
Min. temperature:	-10°C
Pressure	
Max. product pressure:	1000 kPa (10 bar)

With its specially engineered design, YSV is the ideal solution for systems that require frequent inspections and quick servicing.

#### BENEFITS AT A GLANCE

- **Maximum hygiene:** Only the shutter comes into contact with the product. There are no springs, discs or other components which could contaminate it, this means no contamination and no stagnation point.
- **Safe closing:** Ensured by patented magnetic principle.
- **Any installation position possible:** It can be installed in horizontal, vertical up and down positions.
- **Energy saving:** Its innovative working principle and design allow for a smooth flow, minimising pressure drop.
- **Laminar flow:** No turbulence.
- **Maintenance:** Free.
- **Longer valve life:** Thanks to high chemical resistance of the materials.
- **Resistant up to 220°C**
- **No more springs that can break or misfire**
- **No flow obstruction components**
- **No stagnation points**



The main operational difference between a spring-loaded check valve and the innovative YSV valve lies in flow resistance. A conventional check valve, even when fully open, imposes significant resistance because the compressed spring continuously pushes the shutter against the flow with considerable force.

In YSV valve, magnets integrated into the valve body keep the shutter in the closed position. The valve opens when the inlet pressure exceeds the magnetic force. Once open, the shutter moves away from the magnet, resulting in reduced attraction to the seat and significantly lower resistance to flow, which means minimal pressure drop. When the forward flow stops, the magnetic force pulls the shutter back into its seat, effectively preventing any reverse flow.

## TECHNICAL DATA

<b>Product contact materials</b>	Body & Flanges: Stainless steel 1.4404 (AISI 316L) Shutter: 1.4462 (Duplex) – 1.4410 (F53)
<b>Non product contact materials</b>	Magnet: Neodymium
<b>Seals material options</b>	EPDM, VMQ (Silicone), FKM (Viton), PTFE, FEP, HNBR, NBR
<b>Surface finishes</b>	Internal: Ra $\mu\text{m} \leq 0.8$ up to Ra. $\mu\text{m} \leq 0.4$ electropolished and pas-sivated (optional) External: Ra $\mu\text{m} \leq 3.2$ up to Ra. $\mu\text{m} \leq 0.4$ electropolished and pas-sivated (optional)
<b>Dimensions</b>	DN 25 - DN 125   1" - 5"
<b>End connection options</b>	WELDING: DIN 11866-A; ASME BPE; SMS.
<b>Temperature range</b>	-20°C/+150°C (Standard). Up to +220°C (optional)
<b>Operating pressure</b>	PN16 (standard) - PN40
<b>Media</b>	Food & Beverage, Liquid
<b>Certifications (on request)</b>	MATERIAL: EN10204:2005 "3.1" / O-RING: FDA - Declaration of conformity / Surface roughness / PED / EC 1935 / 2004 /ATEX

INSTALLATION	FLOW DIRECTION	OPENING PRESSURE
<b>HORIZONTAL lines</b>	/	30/50 mbar
<b>VERTICAL lines</b>	Top to bottom	27/45 mbar
<b>VERTICAL lines</b>	Bottom to top	33/55 mbar

Once opened, the required pressure to keep the shutter fully open is about 10 mbar.

## PRESSURE DROP CHART

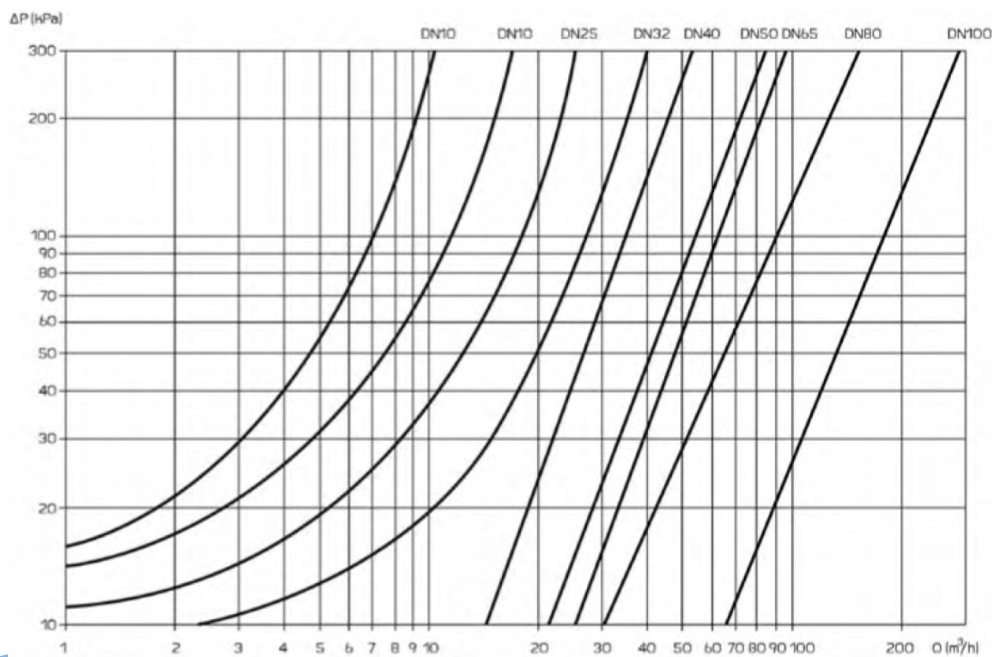

## ORDERING INFO YSV

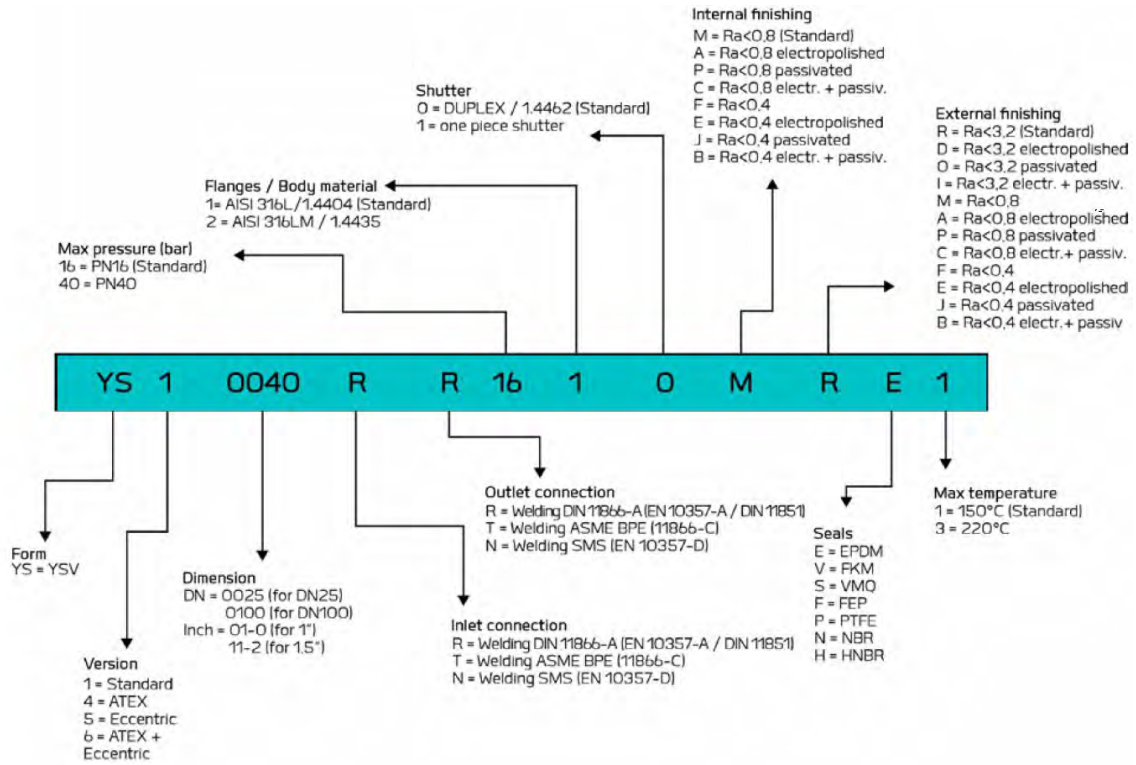

## DIN 11866-A (EN 10357-A / DIN 11851) > R

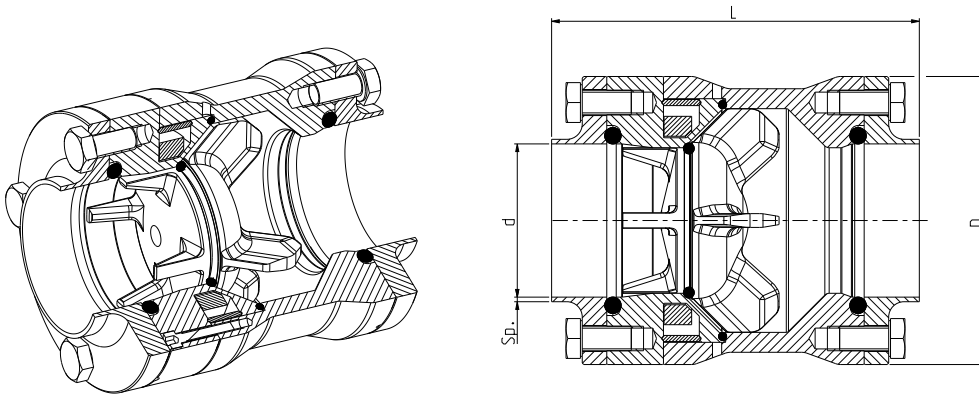

DIMENTION	L (mm)	D (mm)	di (mm)	de (mm)	Sp (mm)	Weight (kg)
DN25	86,5	62	26	29	1,5	1,3
DN40	106	79,5	38	41	1,5	2,3
DN50	120	94	50	53	1,5	3,3
DN65	130	116	66	70	2	5,3
DN80	153,5	134,5	81	85	2	7,8
DN100	163	155	100	104	2	10,1
DN125	184,5	199	125	129	2	18,8

### ASME BPE (DIN 11866 Reihe C) > T

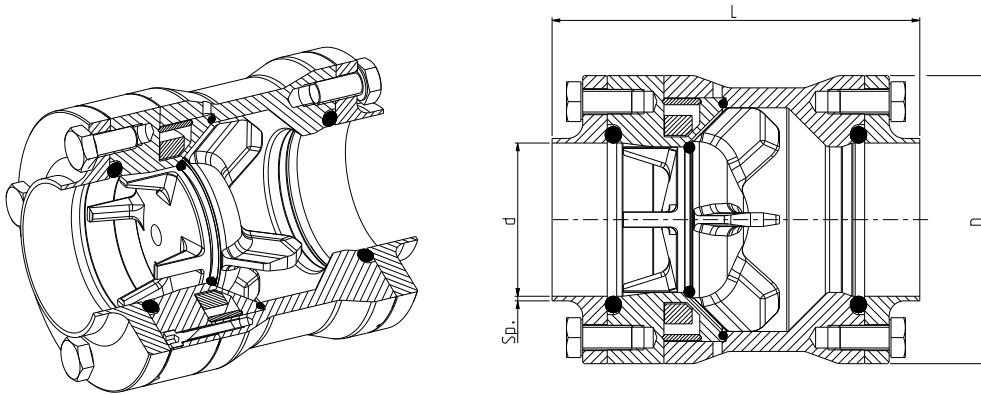

DIMENTION	L (mm)	D (mm)	di (mm)	de (mm)	Sp (mm)	Weight (kg)
1"	86,5	62	22,1	25,4	1,65	1,3
1-1/2"	106	79,5	34,8	38,1	1,65	2,3
2"	120	94	47,5	50,8	1,65	3,3
2-1/2"	130	116	60,2	63,5	1,65	5,3
3"	153,5	134,5	72,9	76,2	1,65	7,8
4"	163	155	97,38	101,6	2,11	10,1
5"	184,5	199	121,46	127	2,77	18,8

### SMS (EN 10357 series D) > N

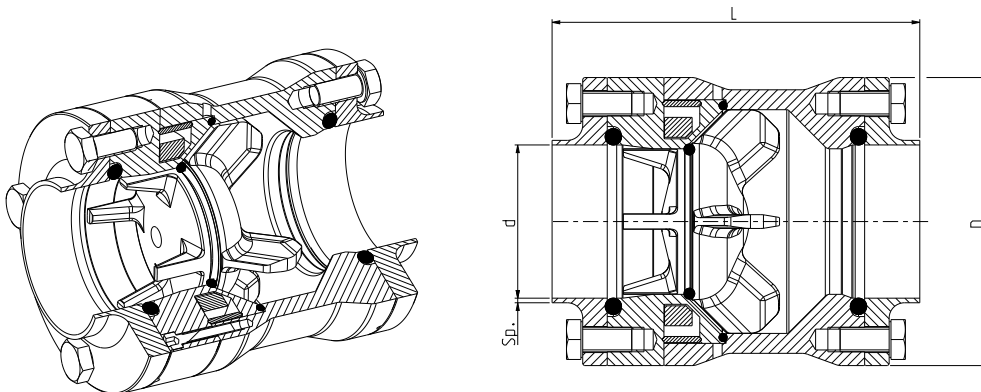

DIMENTION	L (mm)	D (mm)	di (mm)	de (mm)	Sp (mm)	Weight (kg)
DN25	86,5	62	22,6	25	1,2	1,3
DN38	106	79,5	35,6	38	1,2	2,3
DN51	120	94	48,6	51	1,2	3,3
DN63,5	130	116	60,2	63,4	1,6	5,3
DN76,1	153,5	134,5	72,9	76,1	1,6	7,8
DN101,6	163	155	97,38	101,6	2,11	10,1

Sanitary

YSV ECCENTRIC

DIN 11866-A (EN 10357-A / DIN 11851) > R

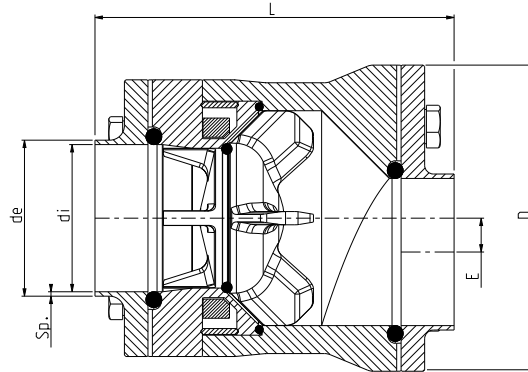
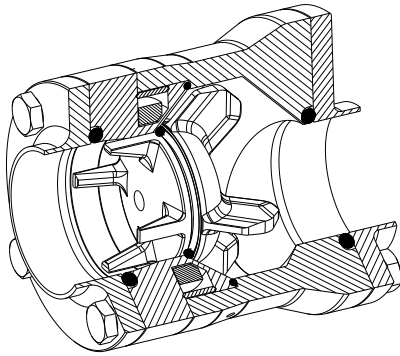

DIMENTION	L (mm)	D (mm)	di (mm)	de (mm)	Sp (mm)	E (mm)	Weight (kg)
DN25	86,5	62	26	29	1,5	6,25	1,2
DN40	107	83,5	38	41	1,5	9,75	2,4
DN50	122	104	50	53	1,5	11,5	4
DN65	134	124	66	70	2	13	5,8
DN80	156	142,5	81	85	2	14,75	8,4
DN100	168	168	100	104	2	15,25	11,4

ASME BPE (DIN 11866 Reihe C) > T

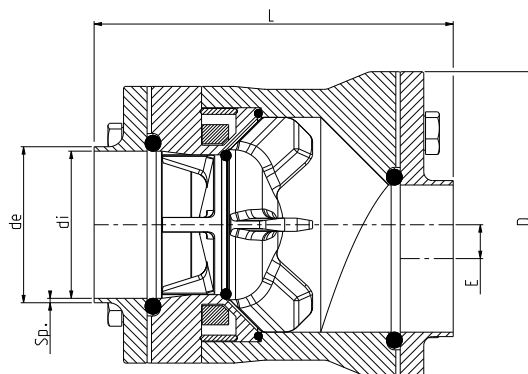
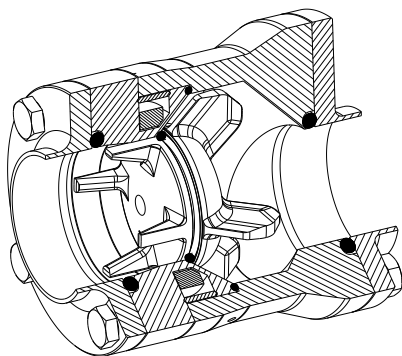

DIMENTION	L (mm)	D (mm)	di (mm)	de (mm)	Sp (mm)	E (mm)	Weight (kg)
1"	86,5	62	22,1	25,4	1,65	6,25	1,2
1-1/2"	107	83,5	34,8	38,1	1,65	11,35	2,4
2"	122	104	47,5	50,8	1,65	11,5	4
2-1/2"	134	124	60,2	63,5	1,65	13	5,8
3"	156	142,5	72,9	76,2	1,65	14,45	8,5
4"	168	168	97,38	101,6	2,11	15,25	11,5

SMS (EN 10357 series D) > N

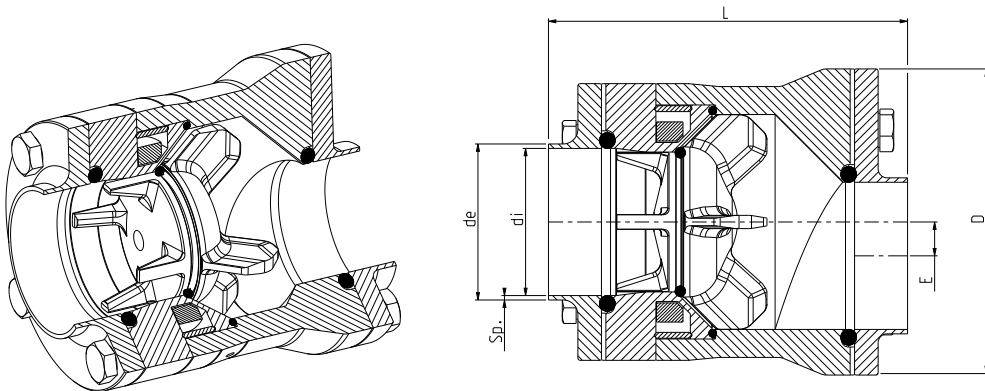

DIMENTION	L (mm)	D (mm)	di (mm)	de (mm)	Sp (mm)	E (mm)	Weight (kg)
DN25	86,5	62	22,6	25	1,2	6,25	1,2
DN38	107	83,5	35,6	38	1,2	10	2,4
DN51	122	104	48,6	51	1,2	12,2	4
DN63,5	134	124	60,3	63,5	1,65	13	5,8
DN76,1	156	142,5	72,9	76,2	1,65	14,45	8,5
DN101,6	168	168	97,38	101,6	2,11	15,25	11,5

**YSV 3-A:** Developed specifically for the U.S. market and certified by the 3-A Sanitary Standards Institute, the YSV 3-A extractable check valve is engineered for effortless maintenance.

Thanks to its specialized design, it is the ideal solution for systems requiring frequent inspections and quick, efficient servicing.

#### BENEFITS AT A GLANCE

- **Maximum hygiene:** Only the shutter comes into contact with the product. There are no springs, discs or other components which could contaminate it, this means no contamination and no stagnation point.
- **Safe closing:** Ensured by patented magnetic principle.
- **Any installation position possible:** It can be installed in horizontal, vertical up and down positions.
- **Energy saving:** Its innovative working principle and design allow for a smooth flow, minimising pressure drop.
- **Laminar flow:** No turbulence.
- **Maintenance:** Free.
- **Longer valve life:** Thanks to high chemical resistance of the materials.
- **Resistant up to 220°C**
- **No more springs that can break or misfire**
- **No flow obstruction components**
- **No stagnation points**



The main operational difference between a spring-loaded check valve and the innovative YSV valve lies in flow resistance. A conventional check valve, even when fully open, imposes significant resistance because the compressed spring continuously pushes the shutter against the flow with considerable force.

In YSV valve, magnets integrated into the valve body keep the shutter in the closed position. The valve opens when the inlet pressure exceeds the magnetic force. Once open, the shutter moves away from the magnet, resulting in reduced attraction to the seat and significantly lower resistance to flow, which means minimal pressure drop. When the forward flow stops, the magnetic force pulls the shutter back into its seat, effectively preventing any reverse flow.

## TECHNICAL DATA

<b>Product contact materials</b>	Body & Flanges: Stainless steel 1.4404 (AISI 316L) Shutter: 1.4462 (Duplex) – 1.4410 (F53)
<b>Non product contact materials</b>	Magnet: Neodymium
<b>Seals material options</b>	EPDM, VMQ (Silicone), FKM (Viton), PTFE, FEP, HNBR, NBR
<b>Surface finishes</b>	Internal: Ra $\mu\text{m} \leq 0.8$ up to Ra. $\mu\text{m} \leq 0.4$ electropolished and pas-sivated (optional) External: Ra $\mu\text{m} \leq 3.2$ up to Ra. $\mu\text{m} \leq 0.4$ electropolished and pas-sivated (optional)
<b>Dimensions</b>	DN 25 - DN 125   1" - 5"
<b>End connection options</b>	WELDING: DIN 11866-A; ASME BPE; SMS.
<b>Temperature range</b>	-20°C/+150°C (Standard). Up to +220°C (optional)
<b>Operating pressure</b>	PN16 (standard) - PN40
<b>Media</b>	Food & Beverage, Liquid
<b>Certifications (on request)</b>	MATERIAL: EN10204:2005 "3.1" / O-RING: FDA - Declaration of conformity / Surface roughness / PED / EC 1935 / 2004 /ATEX

INSTALLATION	FLOW DIRECTION	OPENING PRESSURE
<b>HORIZONTAL lines</b>	/	30/50 mbar
<b>VERTICAL lines</b>	Top to bottom	27/45 mbar
<b>VERTICAL lines</b>	Bottom to top	33/55 mbar

Once opened, the required pressure to keep the shutter fully open is about 10 mbar.

## PRESSURE DROP CHART

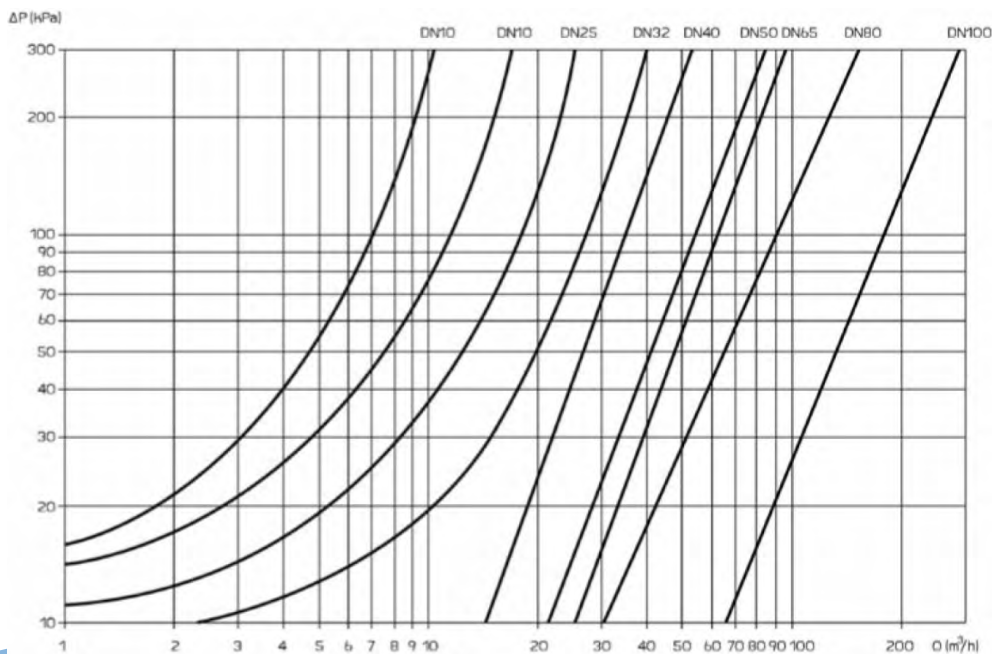

## ORDERING INFO YSV

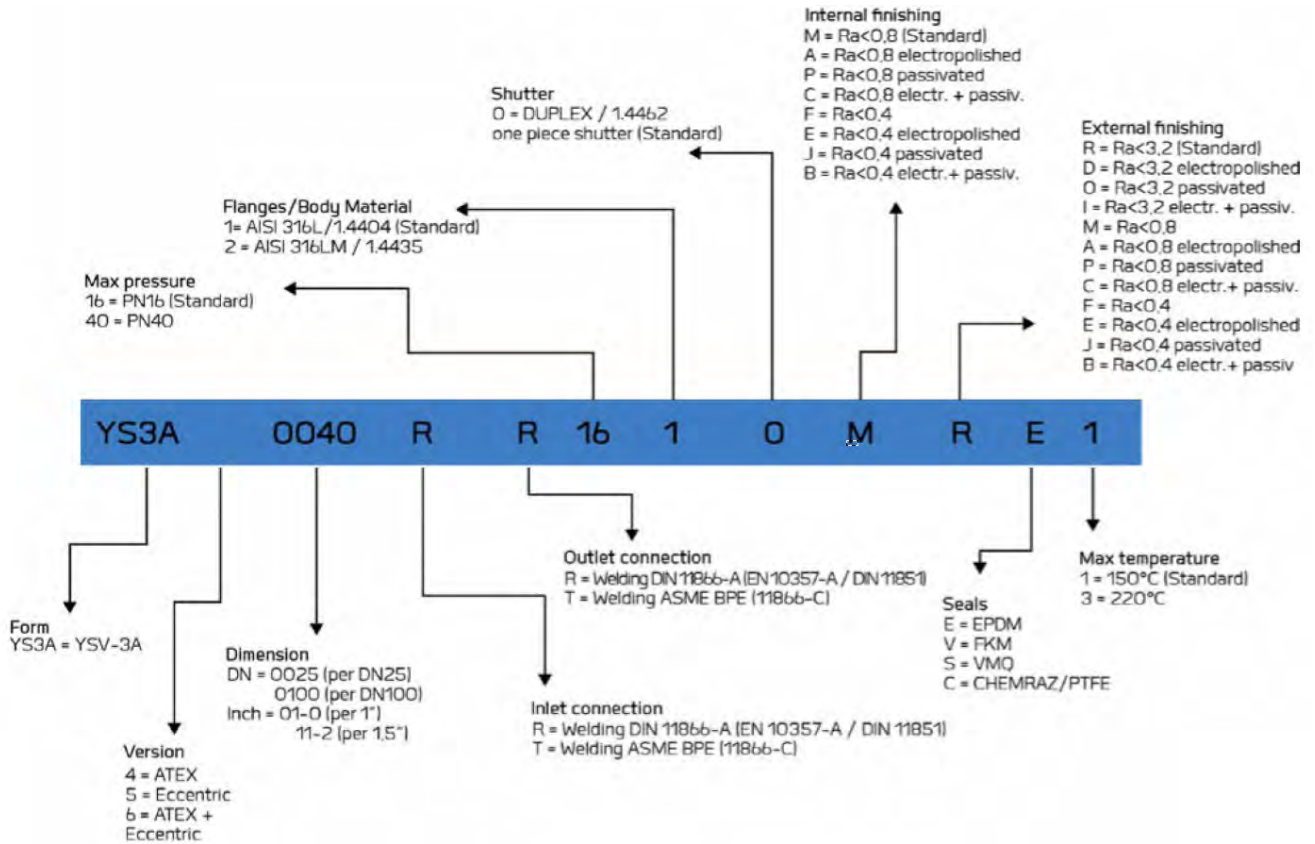

# SEALING SYSTEMS

Engineering Equipment for Sanitary Applications

